

This article was downloaded by:

On: 24 January 2011

Access details: *Access Details: Free Access*

Publisher *Taylor & Francis*

Informa Ltd Registered in England and Wales Registered Number: 1072954 Registered office: Mortimer House, 37-41 Mortimer Street, London W1T 3JH, UK



Journal of Macromolecular Science, Part A

Publication details, including instructions for authors and subscription information:

<http://www.informaworld.com/smpp/title~content=t713597274>

Synthesis of Polymers by Using Fluorene. VI. Free-Radical and Anionic Polymerizations of 9-Fluorenyl and 9-Phenyl-9-fluorenyl Methacrylates

Tsutomu Oishi^a; Minoru Fujimoto^a; Toshizumi Hirota^b; Shoji Kajigaeshi^b

^a Department of Industrial Chemistry, Technical College, Yamaguchi, Japan ^b Department of Industrial Chemistry Faculty of Engineering, Yamaguchi University, Yamaguchi, Japan

To cite this Article Oishi, Tsutomu , Fujimoto, Minoru , Hirota, Toshizumi and Kajigaeshi, Shoji(1986) 'Synthesis of Polymers by Using Fluorene. VI. Free-Radical and Anionic Polymerizations of 9-Fluorenyl and 9-Phenyl-9-fluorenyl Methacrylates', *Journal of Macromolecular Science, Part A*, 23: 6, 687 – 696

To link to this Article: DOI: 10.1080/00222338608063416

URL: <http://dx.doi.org/10.1080/00222338608063416>

PLEASE SCROLL DOWN FOR ARTICLE

Full terms and conditions of use: <http://www.informaworld.com/terms-and-conditions-of-access.pdf>

This article may be used for research, teaching and private study purposes. Any substantial or systematic reproduction, re-distribution, re-selling, loan or sub-licensing, systematic supply or distribution in any form to anyone is expressly forbidden.

The publisher does not give any warranty express or implied or make any representation that the contents will be complete or accurate or up to date. The accuracy of any instructions, formulae and drug doses should be independently verified with primary sources. The publisher shall not be liable for any loss, actions, claims, proceedings, demand or costs or damages whatsoever or howsoever caused arising directly or indirectly in connection with or arising out of the use of this material.

Synthesis of Polymers by Using Fluorene. VI. Free-Radical and Anionic Polymerizations of 9-Fluorenyl and 9-Phenyl-9-fluorenyl Methacrylates

TSUTOMU OISHI and MINORU FUJIMOTO

Department of Industrial Chemistry
Technical College

TOSHIZUMI HIROTA and SHOJI KAJIGAESHI

Department of Industrial Chemistry
Faculty of Engineering

Yamaguchi University
2557 Tokiwadai, Ube, Yamaguchi 755, Japan

ABSTRACT

9-Fluorenyl (FMA) and 9-phenyl-9-fluorenyl methacrylates (PFMA) were prepared from methacryloyl chloride with 9-fluorenol and from silver methacrylate with 9-phenyl-9-fluorenyl chloride, respectively. The polymerizations of FMA and PFMA were studied by using α, α' -azobisisobutyronitrile (AIBN), *n*-butyllithium (*n*-BuLi), and *n*-BuLi-(-)-sparteine (Sp) complex in toluene and tetrahydrofuran (THF). Only PFMA polymers obtained with the *n*-BuLi-Sp complex showed a specific rotation ($[\alpha]_D^{21}$ -3 to -16° in THF).

The number-average molecular weights of the FMA and PFMA polymers were 7 700-16 900 and 1 400-4 700, respectively.

INTRODUCTION

The polymerizations of alkyl and aryl methacrylates with radical and anionic initiators have been extensively studied [1]. Yuki and co-workers reported that triphenylmethyl methacrylate (TrMA) was polymerized with anionic and radical initiators to obtain a highly isotactic polymer regardless of the polymerization medium, the temperature, and the type of initiator [2]. Recently Yuki and co-workers found that an optically active vinyl polymer was formed directly from a vinyl monomer, TrMA, with a chiral anionic catalyst, *n*-BuLi-(-)-Sp complex, and that the specific rotation $[\alpha]_D$ of the polymer obtained with *n*-BuLi-(-)-Sp (sparteine) in toluene was positive and increased with polymer yield, reaching above 300° [3]. They also reported the resolution of racemic compounds by optically active poly(TrMA) [4, 5].

As part of a program on the synthesis of fluorene-containing polymers, we reported the preparation and thermostabilities of polyamide-imides from 2,7-fluorenediamine [6] and 2,7-diamino-9-fluorenone [7], and of polyester-imides, epoxy resins, polyesters, and polycarbonates from 2,7-fluorenediol [8, 9]. In addition, we recently reported on the polymerization of acrylamide and methacrylamide including fluorene derivatives in the side chain [10].

In this article we deal with the synthesis and polymerization of two novel methacrylates, 9-phenyl-9-fluorenyl methacrylate (PFMA) and 9-fluorenyl methacrylate (FMA), with free-radical and anionic initiators. Furthermore, we also report on polymerizations of PFMA and FMA with the *n*-BuLi-(-)-Sp complex.

EXPERIMENTAL

Materials

FMA was synthesized from methacryloyl chloride and 9-fluorenyl (mp 154-156°C, colorless needles) [11] as shown in Scheme 1. A solution of methacryloyl chloride (3.0 g, 0.029 mol) in dry benzene (25 mL) was added dropwise to a solution of a mixture of 9-fluorenyl (5.0 g, 0.02 mol) and triethylamine (3.0 g, 0.03 mol) in dry benzene (150 mL) at room temperature. After the solution was refluxed for 3 h and cooled to room temperature, triethylamine hydrochloride that had precipitated was filtered off. The filtrate was evaporated almost to dryness under reduced pressure, and the concentrate was allowed to stand overnight in a refrigerator. The solids were filtered, washed with petroleum ether, and dried. The crude FMA was recrystallized from petroleum ether to yield colorless needles, 4.7 g (yield 68%) mp 59-61°C. IR (cm⁻¹): 1710 (C=O), 1620 (C=O), 1115 (COO). ¹H-NMR

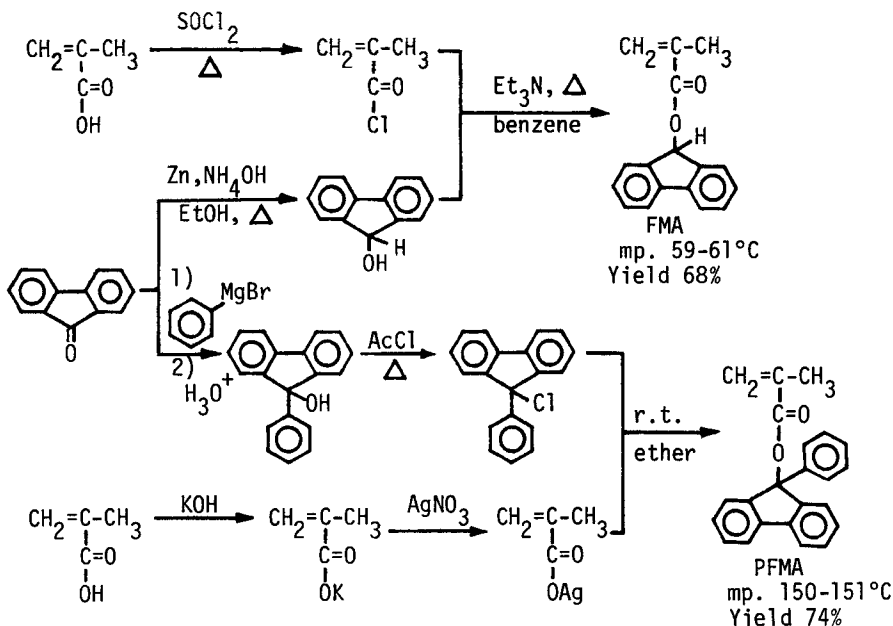

SCHEME 1.

(δ ppm in CDCl_3): 1.98 (s, 3H, CH_3), 5.52 (m, 1H, $\text{H}-\text{C}=\text{C}-\text{CH}_3$), 6.08 (s, 1H, $\text{H}-\text{C}=\text{C}-\text{CH}_3$), 6.77 (s, 1H, 9-H in fluorene), 7.02-8.04

(m, 8H, aromatic protons). Elemental analysis (%): Found: C, 82.02; H, 5.72. Calculated for $\text{C}_{17}\text{H}_{14}\text{O}_2$: C, 81.58; H, 5.64.

PFMA was prepared from silver methacrylate [12] and *o*-phenyl-9-chlorofluorene (mp 73-75°C; Ref. 13, 78-79°C) in dry diethyl ether [14]. Silver methacrylate (20.8 g, 0.11 mol) was added to a solution of 9-phenyl-9-chlorofluorene (29.8 g, 0.11 mol) in 40 mL of dry ether, and the solution was stirred for 10 h at room temperature. The precipitate was filtered off, and the filtrate was evaporated to dryness to obtain crude PFMA. A cyclohexane extract of the filtered precipitate also yielded some additional PFMA. PFMA was recrystallized from cyclohexane/ether to give colorless plate crystals; 25.9 g (yield 74%), mp 150-151°C. IR (cm^{-1}): 1720 (C=O), 1625 (C=C), 1135 (COO). $^1\text{H-NMR}$ (δ ppm in CDCl_3): 1.97 (s, 3H, CH_3), 5.64 (m, 1H, $\text{H}-\text{C}=\text{C}-\text{CH}_3$), 6.29 (s, 1H, $\text{H}-\text{C}=\text{C}-\text{CH}_3$), 7.02-8.09 (m, 13H, aromatic protons). Elemental analysis (%): Found: C, 85.60; H, 5.78. Calculated for $\text{C}_{23}\text{H}_{18}\text{O}_2$: C, 84.64; H, 5.56.

Toluene and tetrahydrofuran (THF) were purified in the usual way. Commercial (-)-sparteine ((-)-Sp) (Sigma Chemical Co.) was dried over CaH_2 and distilled under reduced pressure; bp $160^\circ\text{C}/5$ torr, $n_D^{18} = 1.5280$, $[\alpha]_D^{20} -14.0^\circ$ ($C = 1.0$ g/dL, ethanol). (-)-Sp and *n*-BuLi were mixed in toluene at room temperature just before use.

Polymerization

Polymerizations were carried out in dry glass tubes under dry nitrogen. PFMA or FMA monomer and solvent were placed in the tube, which was then evacuated on a vacuum line and flushed with dry nitrogen. After this procedure had been repeated three times, catalyst solution was added with a syringe to the monomer solution cooled to the polymerization temperature. The reaction was terminated by the addition of a few drops of methanol. The polymer was precipitated in a large amount of methanol and separated by filtration or centrifugation. The product was extracted with THF and separated into a soluble and insoluble fraction. The polymer, which was soluble in THF, was purified by reprecipitating twice from THF/methanol.

Measurements

D-line specific rotations were measured with a Jasco DIP-140 (Japan Spectroscopic Co., Ltd.). Optical rotatory dispersion (ORD) and circular dichroism (CD) data were obtained with a Jasco J-20C (Japan Spectroscopic Co., Ltd.) equipped with a xenon source and a computing data processor. The gel permeation chromatographic (GPC) analysis was accomplished by the same technique as described in an earlier article [15]. IR, ^1H -NMR spectral, and elemental analysis data were obtained by use of the same instruments as reported previously [16].

RESULTS AND DISCUSSION

Results of the anionic polymerization of PFMA with *n*-BuLi are summarized in Table 1. The polymer yield was generally low. Approximately 5-10% of each polymer obtained was soluble in THF. The \bar{M}_n and weight-average molecular weight \bar{M}_w were 1 700-3 300 and 3 300-6 300, respectively. The remainder of each polymer was insoluble both in THF and in common organic solvents. This might be a high-molecular-weight of crosslinked polymer.

Results of the anionic polymerization of PFMA with *n*-BuLi-(-)-Sp complex are summarized in Table 2. The polymers are soluble in THF, in contrast to the polymers obtained with only *n*-BuLi catalyst.

TABLE 1. Polymerization of PFMA with n-BuLi in Toluene

Run	PFMA, mmol	Toluene, mL	n-BuLi, mmol	Polymerization temperature, °C	Polymerization time, h	Yield, %
A-1	1.5	10	0.323	-78	3	3
A-2	1.5	10	0.808	-78	3	20
A-3	1.5	10	0.808	-78	24	34
A-4	1.5	10	0.162	-78	24	6
A-5	6.1	20	1.62	-78	24	20
A-6	0.9	5 ^a	0.162	-78	24	41
A-7	0.9	6	0.097	-78	24	20

^aTHF.

TABLE 2. Polymerization of PFMA with (-)-Sparteine-BuLi Complex in Toluene^a

Run	[Monomer] [Initiator]	Temperature, °C	Time, h	Yield, %	$\bar{M}_n \times 10^{-3}$	$\bar{M}_w \times 10^{-3}$	\bar{M}_w/\bar{M}_n	\bar{DP}	$[\alpha]_D^{21}$, degree	λ_c , nm
B-1	9.5	0	2.0	58	2.7	3.7	1.4	8	0	-
B-2	9.5	-40	3.0	93	3.8	4.6	1.2	12	-8	298.0
B-3	1.9	-78	24.0	72	1.4	1.5	1.0	4	-8	279.0
B-4	3.2	-78	20.5	64	1.9	2.4	1.2	6	-3	322.6
B-5	9.5	-78	3.0	50	1.8	4.1	2.3	5	-6	307.6
B-6	9.5	-78	6.0	44	2.0	2.2	1.1	6	-12	324.4
B-7 ^b	5.7	-78	24.0	79	1.9	4.5	2.3	6	-7	327.4
B-8	18.9	-78	24.0	42	4.2	17.3	4.2	13	-8	352.6
B-9	20.0	-78	24.0	30	4.7	13.3	2.8	14	-16	-
B-10 ^c	11.3	-78	24.0	76	3.8	4.8	1.3	12	0	-
B-11 ^d	19.4	-78	27.0	19	3.1	8.4	2.7	10	-7	306.1
B-12 ^d	19.0	-78	27.0	29	2.7	3.1	1.2	8	-6	-

^a Monomer/solvent, 1/20 (g/mL); [(-)-sparteine]/[n-BuLi], 1.2.^b Monomer/solvent, 1/33 (g/mL).^c Solvent/THF, 20 mL.^d Monomer/solvent, 4/40 (g/mL).

It was confirmed by elemental analysis that (-)-Sp was absent in the polymer. As can be seen from Table 2, the degrees of polymerization (\overline{DP}) of the polymers were low and between 4 and 14. In the polymerizations at 0°C (Run B-1) and in THF (Run B-10), the specific rotations of the polymers obtained were zero. Polymerizations carried out with different $[\text{monomer}]/[\text{initiator}]$ ratios (Runs B-3, B-4, B-8, B-9) exhibited \overline{DP} which increased with increasing monomer concentration and decreasing yields.

The ORD curves were found to fit the simple Drude equation (600–300 nm). The λ_c values for the polymers were between 279 and 352 nm, as shown in Table 2. The specific rotations of the polymers obtained with n-BuLi-(-)-Sp complex in toluene were -3 to -16°. By analogy with the TrMA results reported by Yuki et al. [3], the optical activity of the PFMA polymers might be attributed to a helical conformation. The bulky 9-phenylfluorenyl groups may play an important role in stabilizing the helix. The absolute value of the optical rotation of the PFMA polymer was much smaller than that of the TrMA polymer [3] because the degree of polymerization was so low. The steric hindrance caused in the polymerization by the 9-phenyl-9-fluorenyl group may be much greater than that of the triphenylmethyl group.

Results of the anionic polymerizations of FMA are summarized in Table 3. Specific rotations of the polymers obtained in toluene and THF were zero, which suggests that FMA polymers do not have helical conformations.

Results of the radical polymerizations of PFMA and FMA are summarized in Table 4. The yields at 60°C were higher than those of the other polymerizations, and the degrees of polymerization were slightly higher. These polymers showed no optical activity, in spite of the addition of (-)-Sp (Run D-2).

Yuki, Okamoto, and coworkers reported on the resolution of racemic compounds by optically active TrMA polymer [4]. They showed that TrMA polymer having a degree of polymerization higher than 5 and an absolute value of specific rotation $[\alpha]_D^{20}$ larger than 3 gave much better activity [17]. Since our PFMA satisfied these conditions, attempts to resolve racemic compounds were made. The silanized gel (2.5 g), which was prepared from macroporous spherical silica gel particles, Lichrospher SI 1000 (Merck), and a large excess of dichlorodiphenylsilane, was coated with PFMA polymer (0.8 g) by using THF (12 mL) as solvent, according to the method reported by Okamoto et al. [5]. The PFMA polymer-coated silica gel (about 2.5 g) was slurry packed in a stainless tube [25 × 0.46 cm (i.d.)]. Attempts were made to resolve various racemic compounds, DL-menthol, DL- α -phenylethyl alcohol, DL-mandelic acid, DL-phenylalanine, and DL- α -methylbenzylamine, and 1,1'-bi-2-naphthol with this column (theoretical plate numbers for benzene of 1 800, flow rate of 1.0 mL/min) by using methanol as eluant at 20°C. Resolution was unsuccessful under these conditions. It is possible that the degree of polymerization of the PFMA polymer

TABLE 3. Polymerization of FMA

Run	$\frac{[\text{Monomer}]}{[\text{Initiator}]}$	Temperature, °C	Time, h	Yield, %	$\bar{M}_n \times 10^{-3}$	$\bar{M}_w \times 10^{-3}$	$\frac{\bar{M}_w}{\bar{M}_n}$	\bar{DP}	$[\alpha]_D^{21}$, degree
C-1 ^a	14.8	-78	24.0	87	16.9	98.2	5.8	67	0
C-2 ^b	24.7	-78	24.0	29	7.7	15.5	2.0	31	0

^a Solvent, toluene; initiator, (-)-sparteine-BuLi; monomer/solvent, 1/20 (g/mL); [(-)-sparteine]/[n-BuLi], 1.2.

^b Solvent, THF; initiator, n-BuLi; monomer/solvent, 1/20 (g/mL).

TABLE 4. Free-Radical Polymerization of FMA and PFMA with AIBN in Toluene^a

Run	Monomer, mol/L	Temperature, °C	Time, h	Yield, %	$\bar{M}_n \times 10^{-3}$	$\bar{M}_w \times 10^{-3}$	\bar{M}_w/\bar{M}_n	\bar{DP}	$[\alpha]_D^{20}$, degree
D-1 ^b	PFMA (0.25)	35	48.0	66	3.3	6.3	1.9	10	0
D-2 ^c	PFMA (0.23)	35	24.0	60	2.9	5.1	1.8	9	0
D-3	PFMA (0.23)	60	24.0	83	8.2	29.6	3.6	25	-
D-4	FMA (0.29)	60	24.0	95	9.2	33.4	3.6	37	-

^a[AIBN], 10.6×10 mmol/L; toluene, 10 mL.

^bPhotopolymerization (UV); the sealed ampule was irradiated under a 100-W high-pressure lamp (UVL-300P Rikosha Ltd.) with no shaking at 35°C.

^cPhotopolymerization, (-)-sparteine (0.52 mmol) was added.

is too low, or that the absolute value of the specific rotation of the PFMA polymer is too small.

ACKNOWLEDGMENT

The authors wish to thank Mr M. Momoi for the elemental analysis.

REFERENCES

- [1] For example, D. L. Glusker and R. A. Evans, J. Am. Chem. Soc., **86**, 187 (1964); K. Matsuzaki, A. Ishida, and N. Tateno, J. Polym. Sci., Part C, **16**, 2111 (1967); T. Tsuruta, T. Makimoto, and H. Kanai, J. Macromol. Chem., **1**, 31 (1966).
- [2] H. Yuki, K. Hatada, Y. Kikuchi, and T. Niinomi, J. Polym. Sci., Part B, **6**, 753 (1968).
- [3] Y. Okamoto, K. Suzuki, and H. Yuki, J. Polym. Sci., Polym. Chem. Ed., **18**, 3043 (1980).
- [4] H. Yuki, Y. Okamoto, and I. Okamoto, J. Am. Chem. Soc., **102**, 6358 (1980).
- [5] Y. Okamoto, S. Honda, I. Okamoto, H. Yuki, S. Murata, R. Noyori, and H. Takaya, Ibid., **103**, 6971 (1981).
- [6] M. Fujimoto, T. Oishi, M. Momoi, and S. Murata, Nippon Kagakuishi, p. 1465 (1976).
- [7] M. Fujimoto, T. Oishi, M. Momoi, and S. Murata, Ibid., p. 701 (1977).
- [8] M. Fujimoto, T. Oishi, M. Momoi, and S. Murata, Ibid., p. 1543 (1977).
- [9] T. Oishi, M. Fujimoto, M. Momoi, and S. Murata, J. Polym. Sci., Polym. Chem. Ed., **22**, 2721 (1984).
- [10] T. Oishi and M. Fujimoto, Ibid., **20**, 2727 (1982).
- [11] K. Suzuki, Yukikagoubutsu Gouseihou, **11**, Gihoudou, Tokyo, 1959, p. 18.
- [12] C. F. H. Allen and C. V. Wilson, Organic Syntheses, Collective Volume III, Wiley, New York, 1955, p. 578.
- [13] C. Schlenk and T. O. Bergmann, Ann., **463**, 281 (1928).
- [14] W. E. Bachmann, Organic Syntheses, Collective Volume III, Wiley, New York, 1955, p. 841.
- [15] T. Oishi, M. Fujimoto, and T. Kimura, J. Polym. Sci., Polym. Chem. Ed., **20**, 2999 (1982).
- [16] T. Oishi and M. Fujimoto, Ibid., **20**, 2727 (1982).
- [17] H. Yuki and Y. Okamoto, Patent, Nippon Kokai Tokkyo 57-150432.

Received January 30, 1985

Revision received April 29, 1985